

P/N: FAPL10VL-681Y3R0

RoHS

Outline Dimensions (Unit:mm)

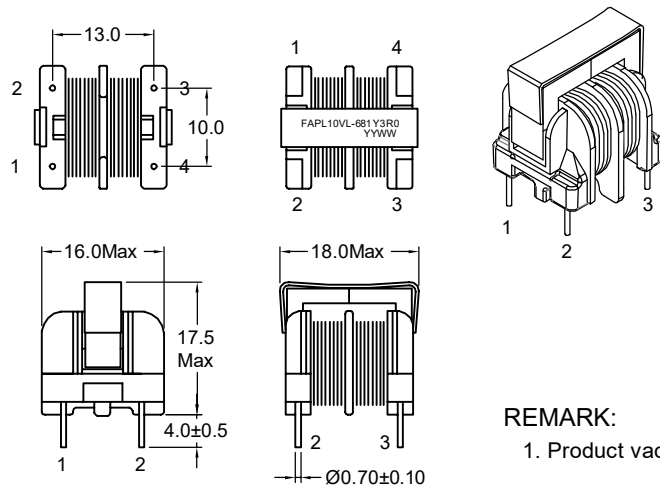

REMARK:
1. Product vacuum impregnation.

Electrical Characteristics

Inductance : 0.68mH Min,at 10KHz,0.1V.
 Rated current : 3.0Amps.
 D.C.Resistance : 50.0 mohms Max.
 Turns Ratio : Wdg1:Wdg2=1:1±1%,at 20KHz,1V.
 Hipot : Coil-Coil : 1500VAC/3mA/2S.

General Properties:

Operating Temperature:-40°C to +125°C
 (Temperature rise included).
 Storage Temperature:-25°C to +85°C.
 Storage Humidity:RH10%~70%.
 Weight: ≈10.0g

Current VS Temp.(Simulation test).

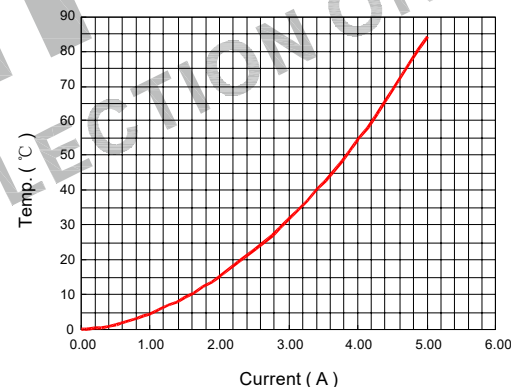

Electronical Schematic

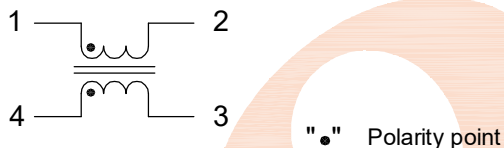

Winding Construction:

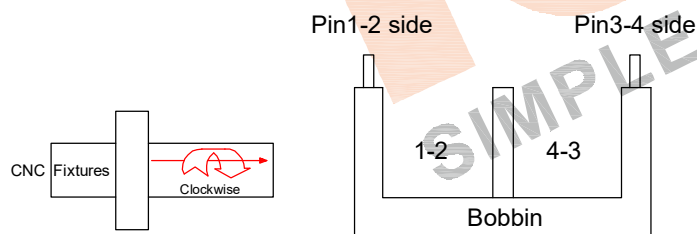

List of UL Certificate:

No.	Part Name	Mat'l Description	Supplier	UL Number
1	Bobbin	UU-1051-1/T375J	Chang Chun Plastics Co Ltd	E59481
2	Copper wire	2UEW-F/155C	Dong Guan YiDa Industrial Co Ltd	E344055
3	Core	UU10.5-H10K	Fuan	N/A
4	Clip	UU10.5/SUS301	Chuangshun Hardware Electronic Factory	N/A
5	Varnish	T-4260(a)/MW80-C	SuZhou TaiHu Electric Advanced Material Co Ltd	E228349

Tianchang Fuan Electronic Co Ltd
 www.fuantronics.net
 TEL: +86-550-7814888
 FAX: +86-550-7831133

Tolerances unless otherwise specified:
 (X)±0.50 (XX)±0.25
 Unit of measurement: mm

Make: *Jun*
 Checked: *BenSon*
 Approved: *AmSon*

DRAWING TITLE
 UU10.5 COMMON-CODE
 FILTER INDUCTOR
 Material Number: A24PL10XA420

Customer P/N:
 Document/Rev: 2201080/00
 Specification Sheet: 1 of 1
 Date of Recognition: Jan./02/2021

REV	DESCRIPTION	APPD	DATE