

P/N: FACSCE2212-220M

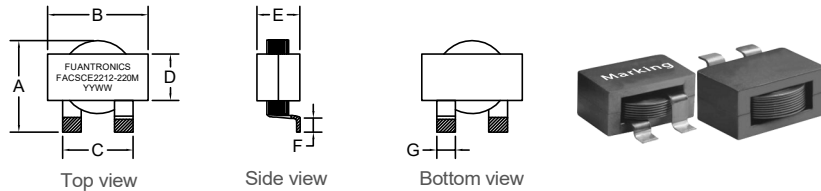

Outline Dimensions(Unit:mm)



A	B	C	D	E	F	G
Max	±0.60	±0.50	±0.30	Max	±0.50	±0.20
22.5	22.6	14.5	14.0	12.0	2.50	4.50

Electronical Schematic

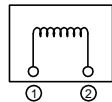

Suggested Pad layout

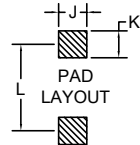

J	5.00 REF
K	6.00 REF
L	10.0 REF

- \*\*\*Assemblage design, sturdy structure.
- \*\*\*Small volume, high current, low magnetic loss, low ESR, small parasitic capacitance.
- \*\*\*Closed magnetic circuit, ultra low buzz noise.
- \*\*\*Temperature rise current and saturation current is less influenced by environment.

Electrical Characteristics(@25°C)

Inductance 100KHz,0.1V	DC Resistor	Saturated current 15A	Temperature rise current 13A
22.0uH±20%	14.0mΩ Max	L(15A)=80%*L0A Typ	T≤40°C Typ

- \*\*\*Saturation current: the actual value of DC current when the inductance decrease 20% of its initial value.
- \*\*\*Temperature rise current: the actual value of DC current when the temperature rise is ΔT40°C(Ta=25°C).
- \*\*\*Operating Temperature: -40°C~+125°C.  
(Temperature rise included)
- \*\*\*Storage Temperature: -40°C~+125°C.
- \*\*\*Storage Humidity:RH10%~70%.

Saturation current VS temperature rise current curve:

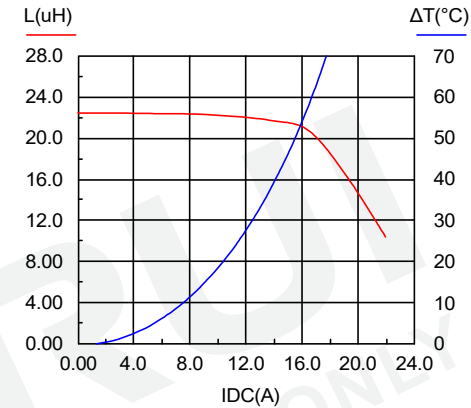

Recommended Soldering Temperature Graph.

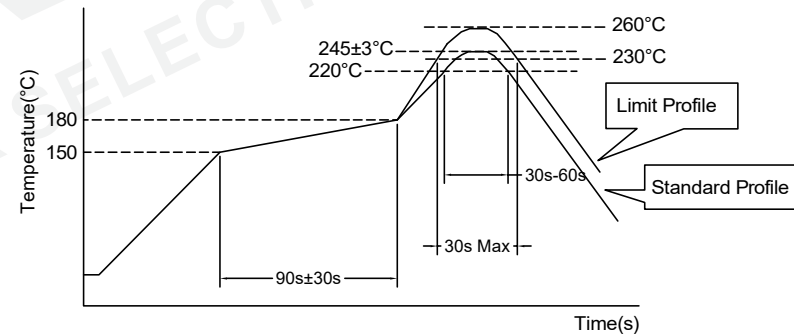

	Standard Profile	Standard Profile
Pre-heating	150~180°C,90s±30s	
Heating	above 220°C,30s-60s	above 240°C,30s Max
Peak temperature	245°C±3°C	260°C,10s
Cycle of reflow	2 times	

REV	DESCRIPTION	APPD	DATE	Tianchang Fuan Electronic Co Ltd www.fuantronics.net TEL: +86-550-7814888 FAX: +86-550-7831133	 Tolerances unless otherwise specified: (.X)±0.50 (.XX)±0.25 Unit of measurement: mm	Make: Qiumei.Liu Checked: Beson. zhan Approved: Anson. zhan	<b>DRAWING TITLE</b> HIGH CURRENT POWER INDUCTORS Material Number: A342212XS080	Customer Name: Document/Rev: 00 Specification Sheet: 1 of 1 Date of Recognition: Jan./02/2020
-----	-------------	------	------	---	---	---	--	--